

stair *TSP100* *futurePRNT*

TSP100LAN

Hardware Manual

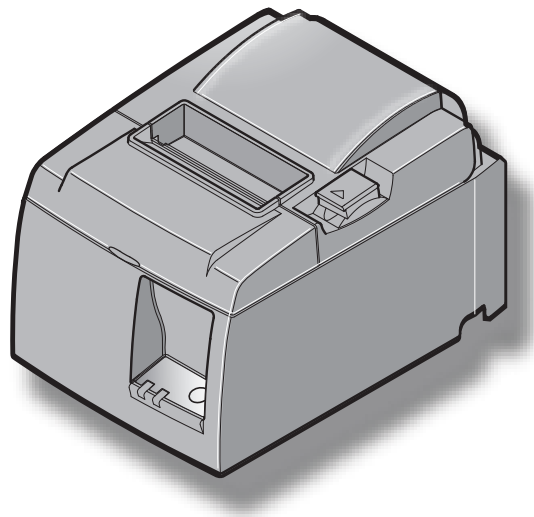

**Federal Communications Commission
Radio Frequency Interference
Statement**

This device complies with Part 15 of the FCC Rules. Operation is subject to the following two conditions: (1) This device may not cause harmful interference, and (2) this device must accept any interference received, including interference that may cause undesired operation.

NOTE: This equipment has been tested and found to comply with the limits for a Class A digital device, pursuant to Part 15 of the FCC Rules. These limits are designed to provide reasonable protection against harmful interference when the equipment is operated in a commercial environment. This equipment generates, uses and can radiate radio frequency energy and, if not installed and used in accordance with the instruction manual, may cause harmful interference to radio communications. Operation of this equipment in a residential area is likely to cause harmful interference in which case the user will be required to correct the interference at his own expense.

This statement will be applied only for the printers marketed in U.S.A.

FCC WARNING

Changes or modifications not expressly approved by the party responsible for compliance could void the user's authority to operate the equipment.

For compliance with the Federal Noise Interference Standard, this equipment requires a shielded cable.

For RF interference suppression, if a ferrite core is provided with this device, affix it to the interface cable

**Statement of
The Canadian Department of Communications
Radio Interference Regulationst**

This Class A digital apparatus complies with Canadian ICES-003.

Cet appareil numérique de la classe A est conforme à la norme NMB-003 du Canada.

The above statement applies only to printers marketed in Canada.

Trademark acknowledgments

TSP100LAN: Star Micronics Co., Ltd.

Notice

- All rights reserved. Reproduction of any part of this manual in any form whatsoever, without STAR's express permission is forbidden.
- The contents of this manual are subject to change without notice.
- All efforts have been made to ensure the accuracy of the contents of this manual at the time of going to press. However, should any errors be detected, STAR would greatly appreciate being informed of them.
- The above notwithstanding, STAR can assume no responsibility for any errors in this manual.

TABLE OF CONTENTS

1. Unpacking and Installation	1
1-1. Unpacking.....	1
1-2. Choosing a place for the printer	2
2. Parts Identification and Nomenclature	3
3. Setup	4
3-1. Connecting the Ethernet Cable to the Printer	4
3-2. Connecting to a Peripheral Unit.....	5
3-3. Loading the Paper Roll.....	6
3-4. Connecting the Ethernet Cable to the PC	10
3-5. Connecting the Power Cord.....	11
3-6. Turning Power On	12
4. Attaching the Accessories	13
4-1. Attaching the Holder Plate	13
4-2. Attaching the Rubber Feet.....	15
4-3. Switch Cover Installation.....	16
5. Thermal Roll Paper Specification	17
5-1. Roll paper specification.....	17
5-2. Recommended paper	17
6. Control Panel and Other Functions	18
6-1. Control Panel.....	18
6-2. Errors.....	18
6-3. Self-Printing	20
7. Preventing and Clearing Paper Jams	21
7-1. Preventing Paper Jams	21
7-2. Removing Paper Jam	21
7-3. Releasing a Locked Cutter (Auto Cutter Mode only)	22
8. Periodical Cleaning	24
8-1. Cleaning the Thermal Head	24
8-2. Cleaning the Rubber Roller	24
8-3. Cleaning the Paper Holder and the Surrounding Area	24
9. Peripheral Unit Drive Circuit	25
10. Specifications	27
10-1. General Specifications.....	27
10-2. Auto Cutter Specifications	28
10-3. Ethernet Interface	28
10-4. Electrical Characteristics	28
10-5. Environmental Requirements	29
10-6. Reliability	30
11. DIP Switch Settings	31

Please access the following URL
<http://www.star-m.jp/eng/dl/dl02.htm>
for the latest revision of the manual.

1. Unpacking and Installation

1-1. Unpacking

After unpacking the unit, check that all the necessary accessories are included in the package.

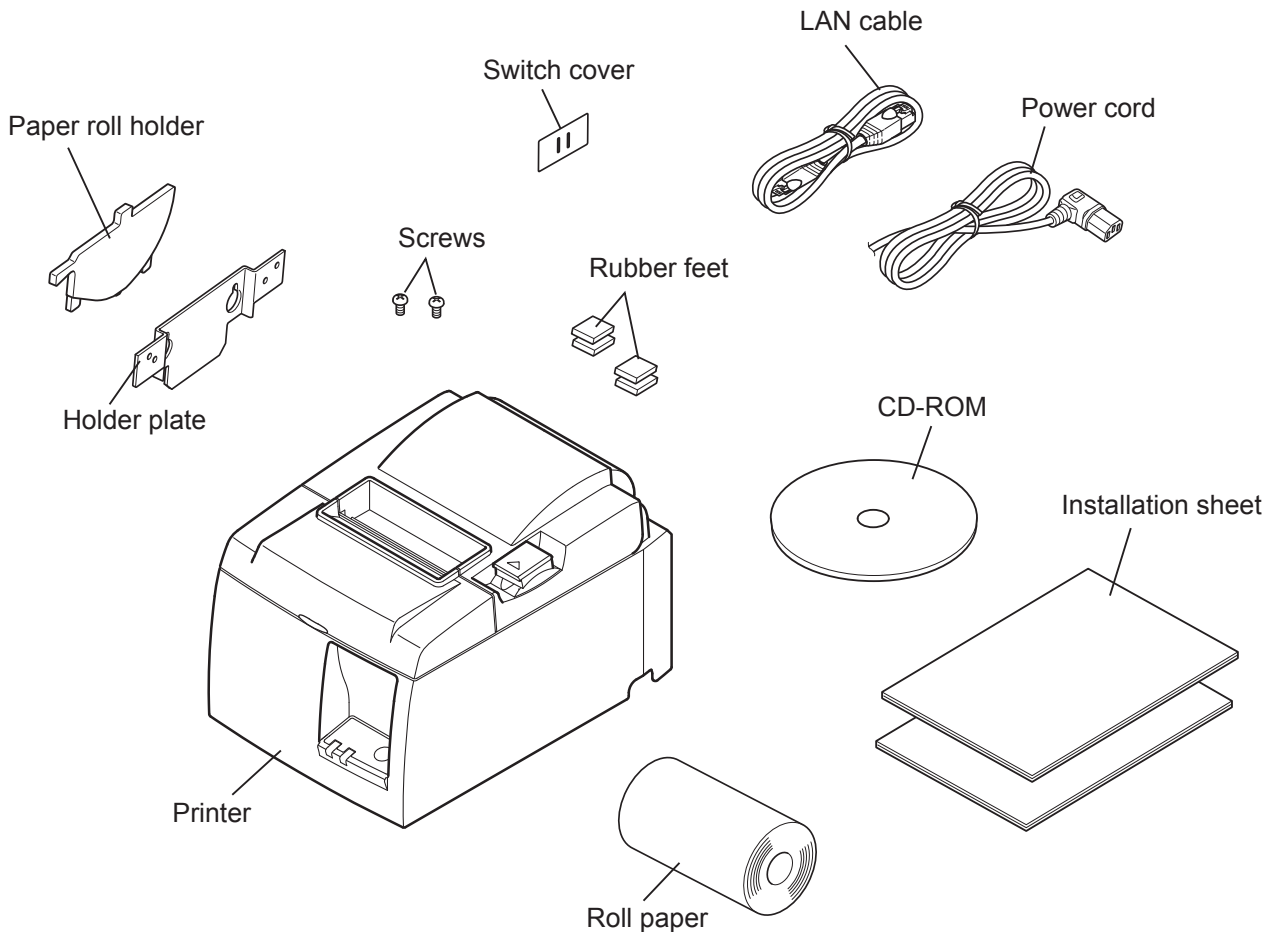

Fig. 1-1 Unpacking

If anything is missing, contact the dealer where you bought the printer and ask them to supply the missing part. Note that it is a good idea to keep the original box and all the packing materials just in case you need to pack the printer up again and send it somewhere at a later date.

1-2. Choosing a place for the printer

Before actually unpacking the printer, you should take a few minutes to think about where you plan to use it. Remember the following points when doing this.

- ✓ Choose a firm, level surface where the printer will not be exposed to vibration.
- ✓ The power outlet you plan to connect to for power should be nearby and unobstructed.
- ✓ Make sure that the printer is close enough to your host computer for you to connect the two.
- ✓ Make sure that the printer is not exposed to direct sunlight.
- ✓ Make sure that the printer is well away from heaters and other sources of extreme heat.
- ✓ Make sure that the surrounding area is clean, dry, and free of dust.
- ✓ Make sure that the printer is connected to a reliable power outlet. It should not be on the same electric circuit as copiers, refrigerators, or other appliances that cause power spikes.
- ✓ Make sure that the room where you are using the printer is not too humid.
- ✓ This device employs a DC motor and switches that have an electrical contact point. Avoid using the device in environments where silicon gas can become volatile.

WARNING

- ✓ Shut down your equipment immediately if it produces smoke, a strange odor, or unusual noise. Immediately unplug the equipment and contact your dealer for advice.
- ✓ Never attempt to repair this product yourself. Improper repair work can be dangerous.
- ✓ Never disassemble or modify this product. Tampering with this product may result in injury, fire, or electric shock.

2. Parts Identification and Nomenclature

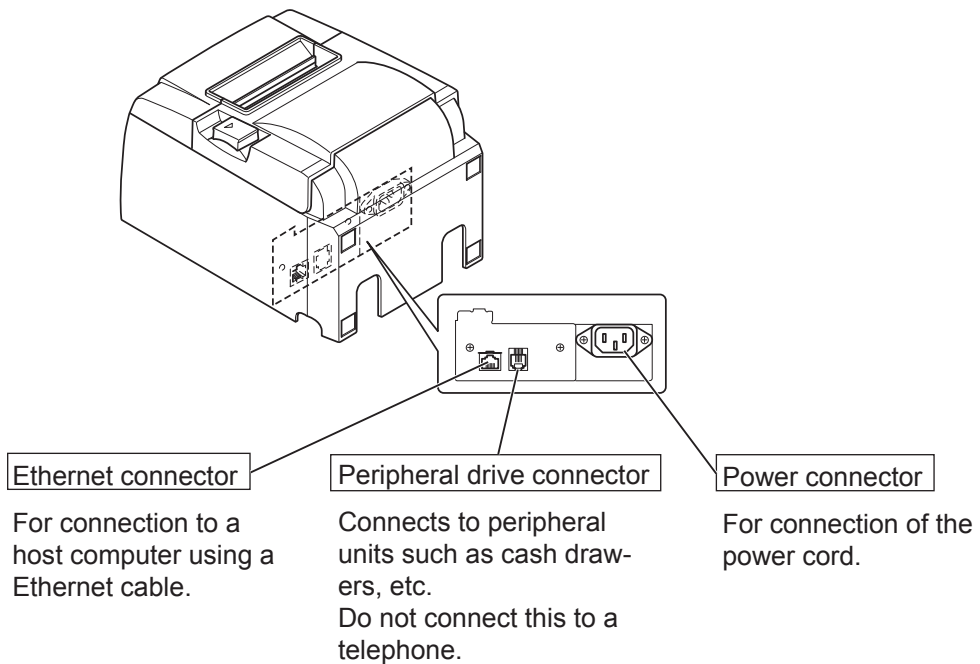
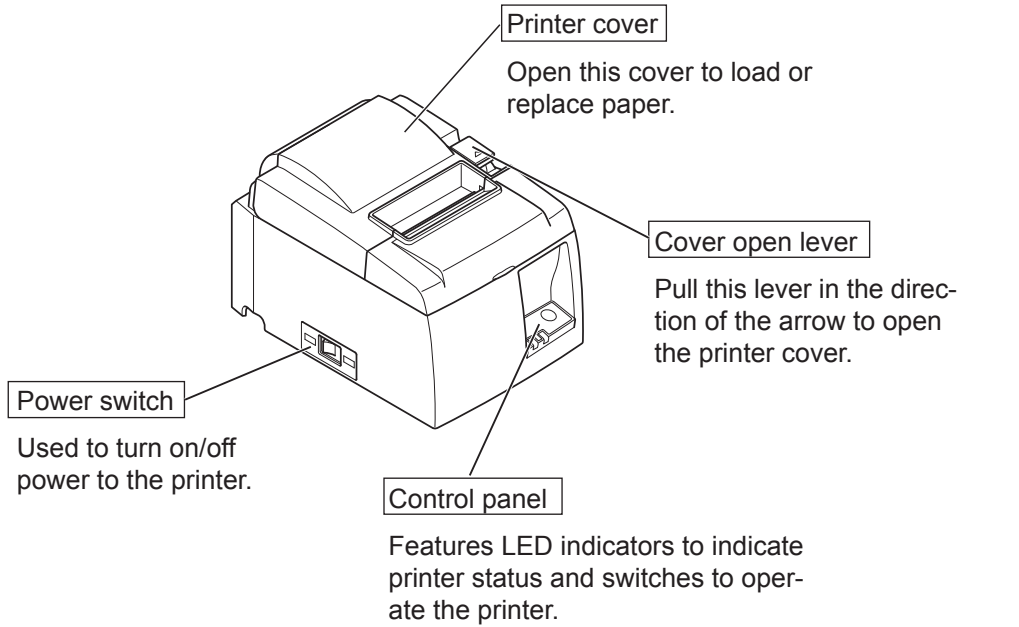

3. Setup

3-1. Connecting the Ethernet Cable to the Printer

- (1) Make sure the printer is turned off.
- (2) Connect the ethernet cable to the connector on the rear panel of the printer.

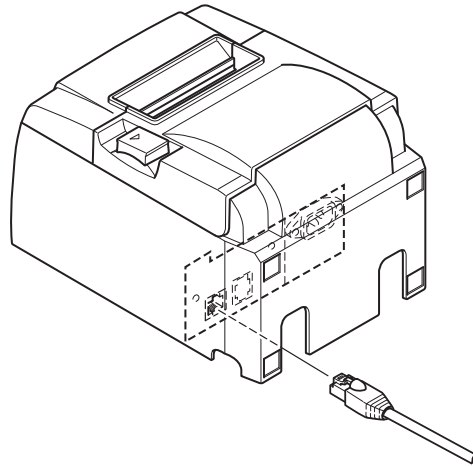

3-2. Connecting to a Peripheral Unit

You can connect a peripheral unit to the printer using a modular plug. The following describes how to install the ferrite core and make the actual connection. See “Modular plug” on page 25 for details about the type of modular plug that is required. Note that this printer does not come with a modular plug or wire, so it is up to you to obtain one that suits your needs.

⚠ CAUTION

Make sure that the printer is turned off and unplugged from the AC outlet and that the computer is turned off before making connections.

- (1) Connect the peripheral drive cable to the connector on the rear panel of the printer.

⚠ CAUTION

Do not connect a telephone line into the peripheral drive connector. Failure to observe this may result in damage to the printer.

Also, for safety purposes, do not connect wiring to the external drive connector if there is a chance it may carry peripheral voltage.

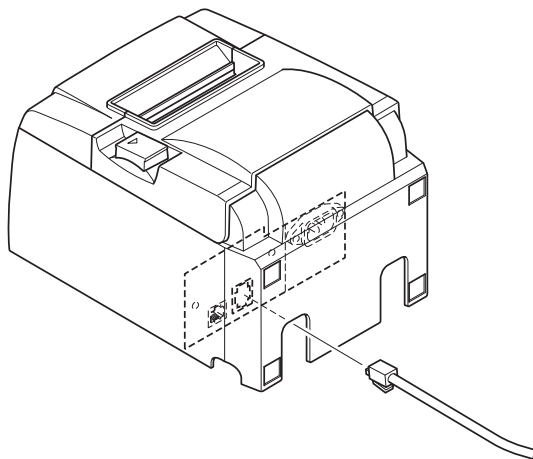

3-3. Loading the Paper Roll

3-3-1. Using 79.5 mm Width Paper Roll

Be sure to use roll paper that matches the printer's specification.

When using a paper roll with an 57.5 mm width, install the paper roll holder as described on the following page.

- 1) Push the cover open lever, and open the printer cover.
- 2) While observing the direction of the roll, set the paper roll into the hollow, and pull on the leading edge of the paper toward you.

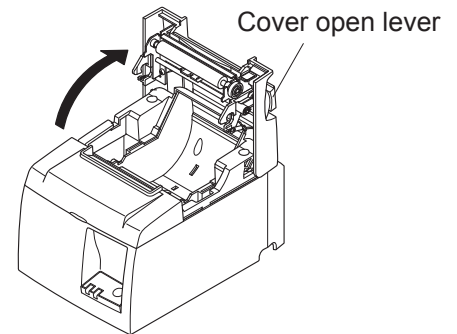

CAUTION

Do not pull out the end of the paper diagonally, as it will cause the paper to become jammed or skewed.

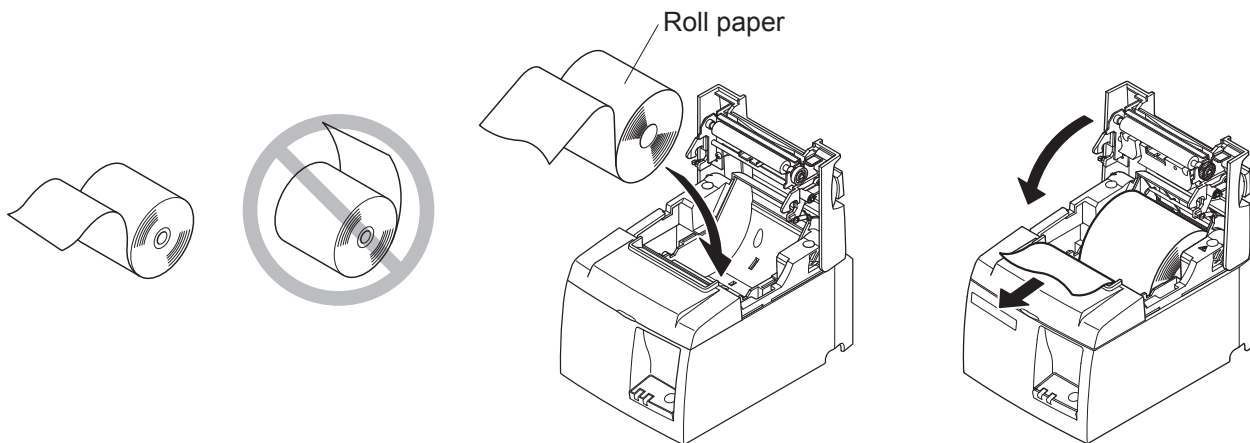

- 3) Push down both sides of the printer cover to close.
Note: Make sure that the printer cover is securely closed.

- 4) **Tear Bar Model:**

Tear off the paper as shown.

Auto Cutter Model:

If the printer cover is closed after turning on the power, the cutter operates automatically and the front end of the paper is cut.

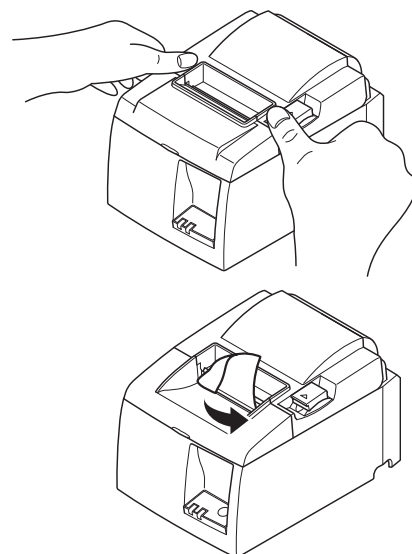

Tear Bar Model

3-3-2. Using 57.5 mm Width Paper Roll

When using a paper roll with 57.5 mm width, install the supplied paper guide on the printer. To change the effective print width (roll paper width), change the setting of the Print Width in the Configuration. For details on the setting of the Print Width, refer to the software manual located in the “Documents” folders on the CD-ROM.

- ① Insert the paper guide along the groove in the unit as shown.

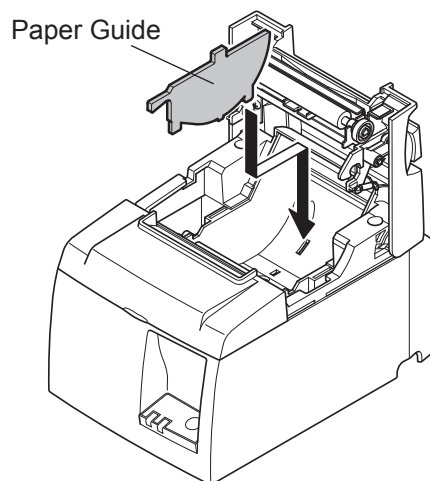

- ② Insert the paper guide by pushing the area marked “A” down until it clicks into place.

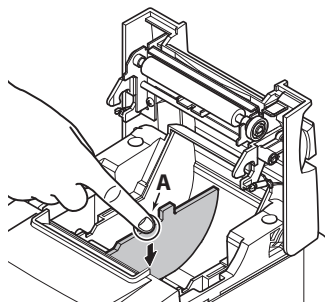

Note: After using a paper roll with a width of 57.5 mm, do not change to a paper roll with a width of 79.5 mm. (This is because the printer head has deteriorated as a result of a portion of the head having been in direct contact with the platen.)

WARNING

- 1) *Do not touch the cutter blade.*
 - *There is a cutter inside the paper outlet slot. Not only should you not put your hand in the paper outlet slot while printing is in progress, never put your hand into the outlet even when printing is not in progress.*
 - *The printer cover can be opened when replacing the paper. However, since the cutter blade is on the inside of the printer cover, be careful not to place your face or hands too close to the cutter blade.*
- 2) *During and immediately after printing, the area around the thermal head is very hot. Do not touch it, as you could be burned.*

Caution Symbol



These labels are located near the thermal print head.

Because the thermal print head is hot immediately after printing, do not touch it. Static electricity can damage the thermal print head. To protect the thermal print head from static electricity, do not touch it.



This symbol is placed near the cutter.

Never touch the cutter blade, as you could injure your fingers.



This symbol is placed near the peripheral drive connector.

Do not connect this to a telephone.



This symbol label or stamp is placed near the screws securing the case or the protective plate, which should not be opened by individuals other than service personnel. Individuals, other than service personnel, should not remove these screws. High voltage areas in the case can be dangerous.

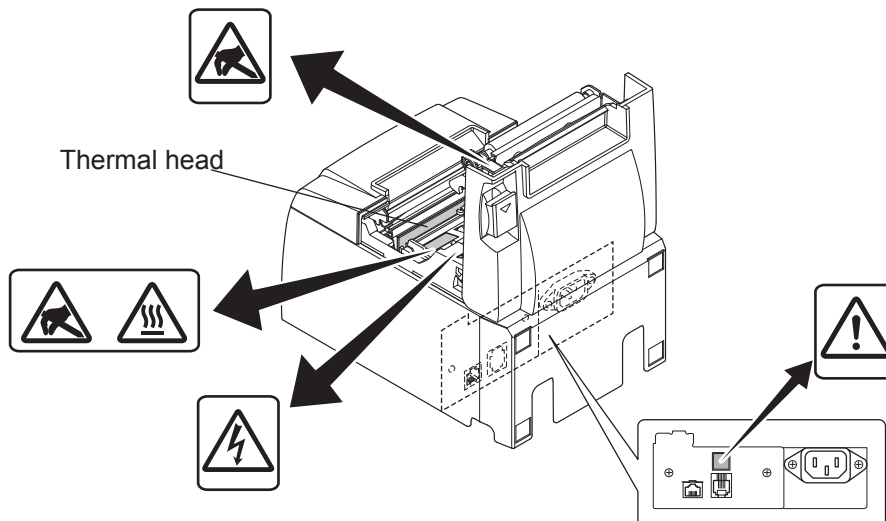

⚠ CAUTION

- 1) *Do not operate the cover open lever while pressing on the printer cover with your hand.*
 - 2) *Do not push the cover open lever and open the printer cover when printing is in progress or when the auto cutter is operating.*
 - 3) *Do not push out paper while the printer cover is closed.*
 - 4) *The heating element and the driver IC of the thermal head are easily damaged. Do not touch them with metal objects, sandpaper, etc.*
 - 5) *Printing quality may suffer if the thermal head heating element becomes soiled by being touched with your hands. Do not touch the thermal head heating element.*
 - 6) *There is a risk of damage to the driver IC of the thermal head from static electricity. Never directly touch the IC.*
 - 7) *The printing quality and working life of the thermal head cannot be guaranteed if any paper other than that recommended is used. In particular, paper containing [Na⁺, K⁺, Cl⁻] may drastically reduce the working life of the thermal head. Please exercise caution.*
 - 8) *Do not operate the printer if there is moisture on the front surface of the head from condensation, etc.*
 - 9) *A printed piece of thermal paper may become electrically charged. If the printer is placed vertically or mounted on a wall, the cut piece of paper may stick to the printer, instead of falling. Beware that this could cause a problem if you use a stacker that stores the pieces of paper that fall freely.*
 - 10) *Do not change the paper width during use. The thermal printing head, rubber roller, and cutter wear differently according to the paper width. This can cause the printing or cutter movement to malfunction.*
 - 11) *Do not transport the printer with its cover open and holding it by the cover.*
 - 12) *Do not forcibly pull on the interface cable, power cable, or cash drawer cable that is connected. To detach a connector, make sure to grasp it at the connector portion, without applying excessive stress on the connector at the printer.*
-

⚠ Notes on Using the Auto Cutter

- 1) *To print after a cut, feed 1 mm (8-dot line) or more of paper.*
 - 2) *If the cutter is not in its home position after an error, first eliminate the cause of the error; then, turn the power back ON.*
 - 3) *A margin of 5 mm or more is recommended from the end of the printed area to the cutting position.*
 - 4) *Do not attempt to remove the paper during a cut, as this can cause a paper jam.*
-

3-4. Connecting the Ethernet Cable to the PC

Connect the ethernet cable to a Ethernet port of your router (or hub or switch).

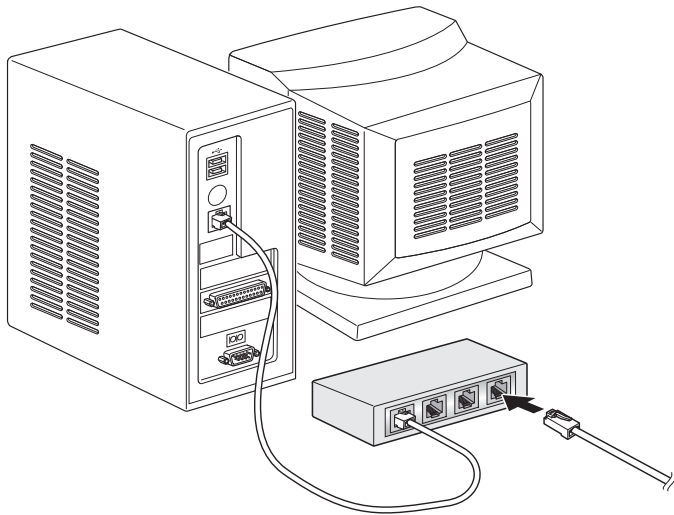

3-5. Connecting the Power Cord

Note: Before connecting/disconnecting the power cord, make sure that power to the printer and all the devices connected to the printer is turned off. Also make sure the power cable plug is disconnected from the AC outlet.

- (1) Check the label on the back or bottom of the printer to make sure its voltage matches that of the AC outlet. Also make sure the plug on the power cord matches the AC outlet.
- (2) If the power cord is not attached to the printer, plug the appropriate end into the AC inlet on the back of the printer.
- (3) Plug the power cord into a properly grounded AC outlet.

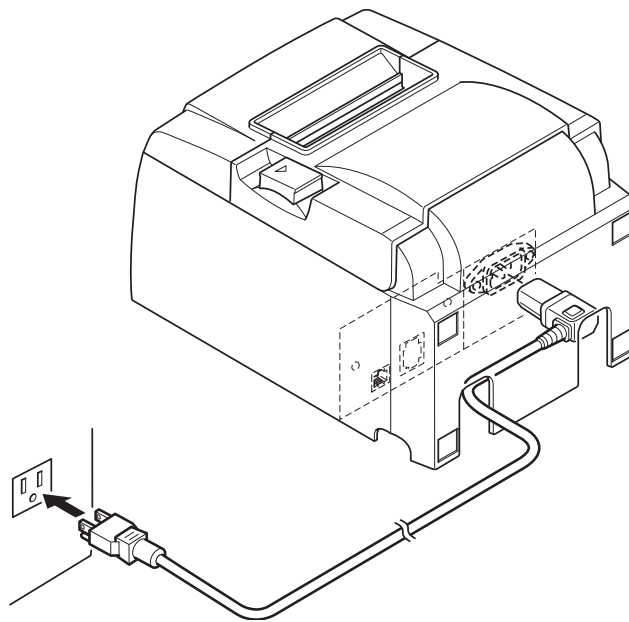

⚠ CAUTION

If the voltage shown on the label on the bottom of your printer does not match the voltage for your area, contact your dealer immediately.

3-6. Turning Power On

Make sure that the Power cord has been connected as described in 3-6.

- (1) Turn ON the power switch located on the front of the printer.
The POWER lamp on the control panel will light up.

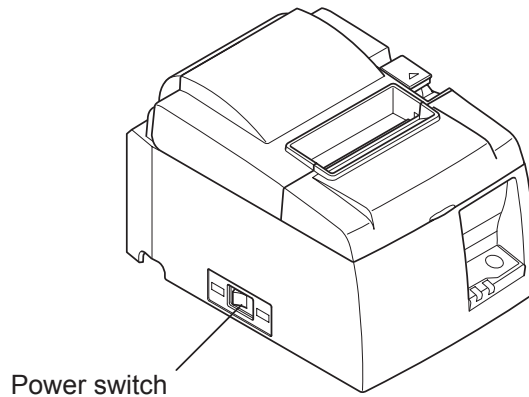

⚠ CAUTION

We recommend that you unplug the printer from the power outlet whenever you do not plan to use it for long periods. Because of this, you should locate the printer so that the power outlet it is plugged into is nearby and easy to access.

When an Switch cover is affixed to the printer above the power switch, the ON/OFF marks of the power switch may be hidden. If this occurs, remove the power cord from the outlet to turn the printer OFF.

4. Attaching the Accessories

The following accessories are necessary when mounting the printer to a wall.

- Holder plate

The following accessories are necessary when positioning the printer vertically.

- Rubber feet

The following accessories do not necessarily have to be attached.

Attach them if necessary.

- Switch cover

4-1. Attaching the Holder Plate

- The holder plate is attached to the printer using the included screws and is hooked onto screws that are installed into the wall.
- The screws on the wall are not included.
Use commercially available screws (4 mm diameter) that are suitable for the wall material (wood, steel beam, concrete, etc.).
- The printer's weight is approximately 2.4 kg when the largest diameter roll paper is loaded.
Use screws on the wall that have both shear strength and pulling-out strength to withstand a force of at least 12 kgf (118 N).

Precautions regarding installation

CAUTION

This caution indicates information that, if ignored, could lead to personal injury or property damage.

- *Be sure to have qualified personnel install the specified screws and printer to the wall. Star is not responsible for any accidents or injuries that occur as a result of improper installation, misuse, or modifications.
Especially when installing the printer at a high location, make sure that the printer is securely installed to the wall.
If the printer is not installed securely and falls, personal injury or damage to the printer may result.*
- *Make sure that the mounting surface and installation screws are strong enough to install the printer.
Securely install the printer so that the weight of the printer and any connected cables will not cause the printer to fall.
Otherwise, personal injury or damage to the printer may result.*
- *Do not install the printer in an unstable location or a location that is exposed to vibration and shocks.
If the printer falls, personal injury or damage to the printer may result.*

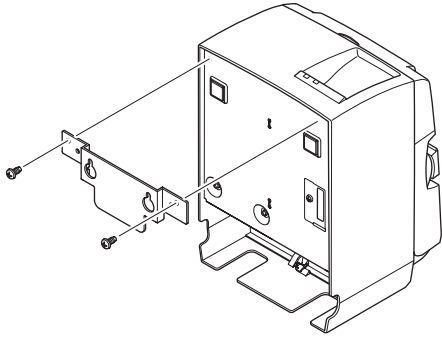

- (1) Attach the holding plate to the printer. Then tighten the two screws that were supplied to secure it in place.

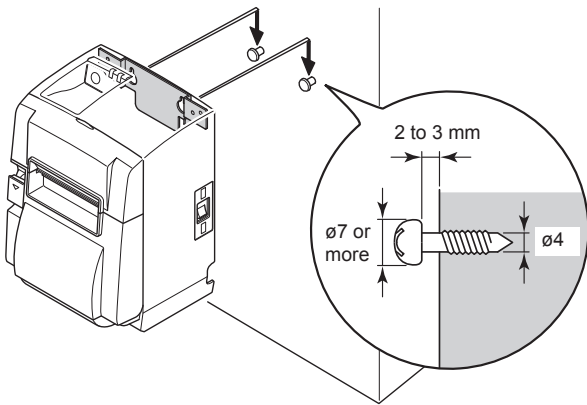

- (2) Position the printer over the screws, etc., on the wall and then slide it downward to set it in place. After setting the printer in place, check the screws on the wall again to make sure that they are able to support the printer's weight.

⚠ CAUTION

- *The printer's weight is approximately 2.4 kg when the largest diameter roll paper is loaded.*
 - *Use screws on the wall that have both shear strength and pulling-out strength to withstand a force of at least 12 kgf (118 N).*
-

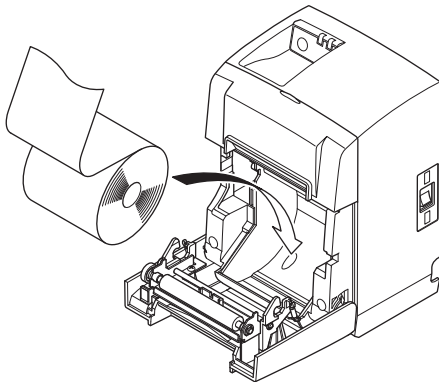

- (3) Push the cover open lever, and open the printer cover.
- (4) Insert the roll paper as shown.

4-2. Attaching the Rubber Feet

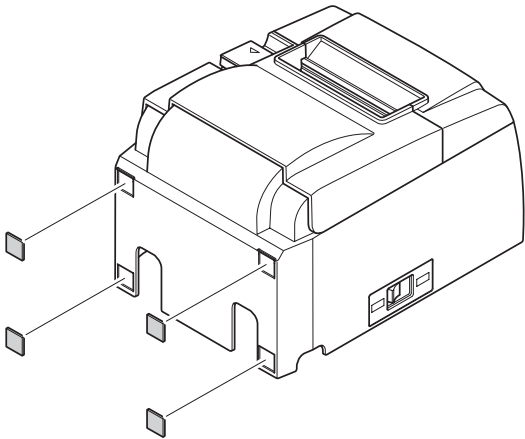

- (1) Attach the four rubber feet in the positions shown in the figure. Ensure that any soiling has been completely wiped off before attaching the rubber feet.

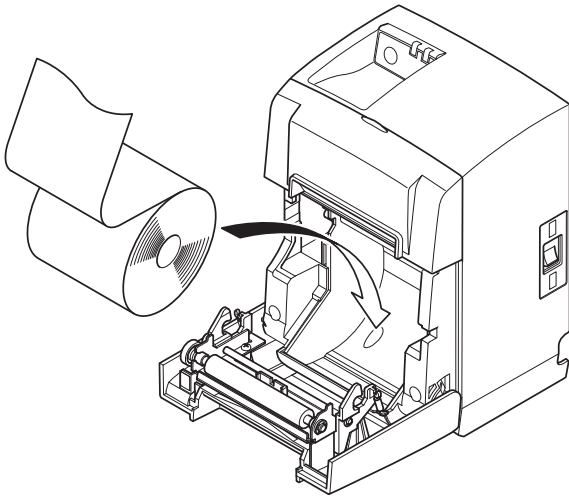

- (2) Push the cover open lever, and open the printer cover.
- (3) Insert the roll paper as shown.

4-3. Switch Cover Installation

It is not necessary to install the switch cover. Only install it if it is necessary for you. By installing the switch cover, the following become possible.

- Preventing the power switch from being operated by mistake.
- Ensuring that other people can not easily operate the power switch.

Install the switch cover as shown in the diagram below.

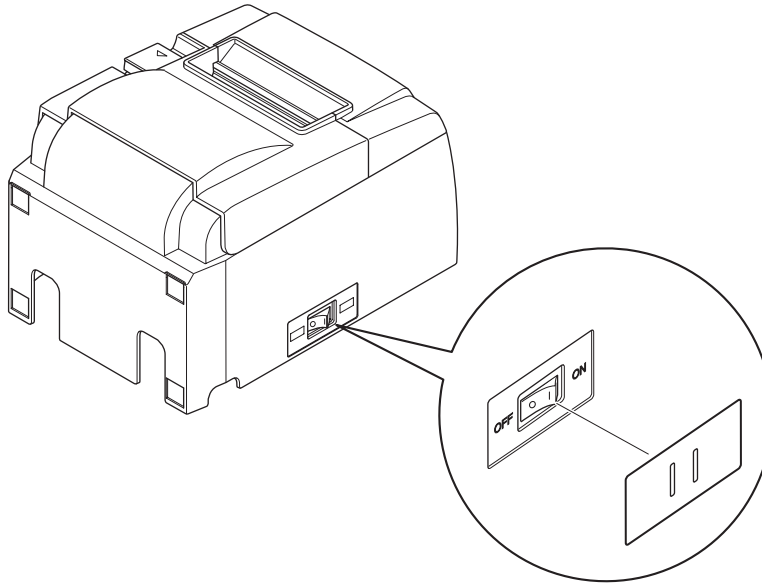

The power switch can be turned ON (I) and OFF (O) by inserting a narrow instrument (ball pen etc.) in the holes in the switch cover.

⚠ CAUTION

We recommend that you unplug the printer from the power outlet whenever you do not plan to use it for long periods. Because of this, you should locate the printer so that the power outlet it is plugged into is nearby and easy to access.

5. Thermal Roll Paper Specification

When consumable parts have run out, use those specified below.

5-1. Roll paper specification

Thermal paper

Thickness: 57~85 μm

Note: When using thin paper with a thickness of less than 65 μm , only the F5041 (Mitsubishi HiTec Paper Flensburg GmbH), TF50KS-E2D (Nippon Paper Industries) and P300/P310 (KSP) paper types are recommended.

Width: 79.5 \pm 0.5 mm (57.5 \pm 0.5 mm when the paper roller holder is used)

Outer roll diameter: ϕ 83 mm or less

Take up paper roll width: 80 $^{+0.5}$ mm or (58 $^{+0.5}$ mm when the paper roller holder is used)

Core outer/inner diameter

Core outer

ϕ 18 \pm 1 mm

Core inner

ϕ 12 \pm 1 mm

Printed surface: Outer edge of roll

Tail end handling: Do not use paste or glue to secure the roll paper or its core.
Do not fold the tail end of the paper.

5-2. Recommended paper

- Note:**
- 1) The print density may vary depending on the type of roll paper, operating environment, and power consumption mode.
 - 2) A reader or scanner may not be able to scan a printed bar code or characters depending on the print density. Make sure that your reader or scanner is able to scan correctly beforehand.

Manufacturer	Product name	Quality characteristics/Use	Paper thickness (μm)
Mitsubishi Paper Mills Limited	P220AG	normal type paper	65 (thickness)
	HP220A	high image stability paper	65 (thickness)
	HP220AB-1	high image stability paper	75 (thickness)
Mitsubishi HiTec Paper Flensburg GmbH	F5041	normal type paper	60 (thickness)
Oji Paper Co., Ltd.	PD150R	normal type paper	75 (thickness)
	PD160R	high image stability paper	75 (thickness)
	PD170R	high image stability paper	75 (thickness)
	PD190R	middle image stability paper	75 (thickness)
Nippon Paper Industries	TF50KS-E2D	normal type paper	59 (thickness)
Kanzaki Specialty Papers Inc. (KSP)	P320RB	2 color paper: Red & Black	65 (thickness)
	P320BB	2 color paper: Blue & Black	65 (thickness)
	P300/P310	normal type paper	57/58 (thickness)

Note: The P300/P310 (KSP) paper types cannot be used when the printer is positioned vertically.

Note: Access the following URL for the information of the recommended paper.

<http://www.star-m.jp/eng/dl/dl02.htm>

6. Control Panel and Other Functions

6-1. Control Panel

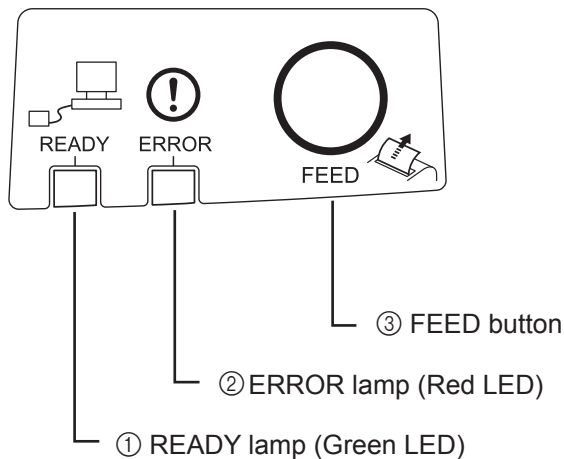

- ① READY lamp (Green LED)
Lights when the power is ON.
- ② ERROR lamp (Red LED)
Indicates various errors in combination with POWER lamp.
- ③ FEED button
Press the FEED button to feed roll paper.

6-2. Errors

1) Automatically recoverable errors

Error Description	READY Lamp	ERROR Lamp	Recovery Conditions
Head high temperature detection	Flashes at 0.5-second intervals	Off	Automatically recovered after the print head has cooled.
Board high temperature detection	Flashes at 2-second intervals	Off	Automatically recovered after the board has cooled.
Cover open error		On	Automatically recovered after the printer cover is closed.

2) Non-recoverable errors

Error Description	READY Lamp	ERROR Lamp	Recovery Conditions
Head thermistor error	Flashes at 0.5-second intervals	Flashes at 0.5-second intervals	Non-recoverable
Board thermistor error	Flashes at 2-second intervals	Flashes at 2-second intervals	Non-recoverable
VM voltage error	Off	Flashes at 1-second intervals	Non-recoverable
VCC voltage error	Flashes at 1-second intervals	Flashes at 1-second intervals	Non-recoverable
EEPROM error	Flashes at 0.25-second intervals	Flashes at 0.25-second intervals	Non-recoverable
CPU error	Off	Off	Non-recoverable
RAM error	Off	On	Non-recoverable

Note:

1. If a non-recoverable error occurs, turn the power OFF immediately.
2. If a non-recoverable error occurs, please consult the dealer for repairs.

3) Paper cut error

Error Description	READY Lamp	ERROR Lamp	Recovery Conditions
Paper cut error	Off	Flashes at 0.125-second intervals	Recovered by turning the power OFF, eliminating the cause of the error such as jammed paper, returning the cutter to its home position, and turning the power ON (see 7-3).

Note: If the cutter does not return to its home position or does not perform the initial movement, it will result in a non-recoverable error.

4) Paper detection error

Error Description	READY Lamp	ERROR Lamp	Recovery Conditions
Paper out error	/	Flashes at 0.5-second intervals	Automatically recovered by loading a new paper roll, then closing the printer cover.

5) Network errors

Error Description	READY Lamp	ERROR Lamp	Status	Recovery Conditions
Network Connection Normal	On	/	TCP/IP Communications Possible	
Network Not Connected (Physically Disconnected)	Two flashes (at 0.125-second intervals) repeated every two seconds	/	Physically disconnected(The Ethernet link is down.)	Check the cable and hub/router, then restart the power.
Network Not Connected (No IP Address)	Flashes at 0.125-second intervals	/	Could not attain IP address when in DHCP/BOOTP.	Check the DHCP/BOOTP server. Then restart the power.
			When static IP address setting value error	Initialize the settings using the DIP switch, then restart with the correct value.

6-3. Self-Printing

Test Printing

Turn the power ON while holding the FEED button depressed. Test printing is performed. The version number, the switch settings and the network informations are printed. After the printer starts printing, release your hand from the FEED button. After self-printing is completed, the printer will start in the normal mode.

```
*** TSP100LAN
    Ver.100.100.100
Unit   : Cutter
        FEDCBA9876543210
<2>    0000000000000000
<4>    0000000000000000
Cutter : Enable
<DSW1> 1234
    On   ****
    Off
```

```
*****
                Network Configuration
*****
```

```
MAC Addr : 00:11:62:00:03:1B

IP Address      :0.0.0.0
Subnet Mask     :0.0.0.0
Default Gateway :0.0.0.0
DHCP/BOOTP     :ENABLE

"user" Login Password : "guest"
"root" Login Password : "*****"
9100 Multi Session  :ENABLE
```

```
*****
                Current IP Parameters Status
*****
IP Address      :192.168.32.196 (DHCP)
Subnet Mask     :255.255.255.0
Default Gateway :192.168.32.254
```

7. Preventing and Clearing Paper Jams

7-1. Preventing Paper Jams

The paper should not be touched during ejection and before it is cut.

Pressing or pulling the paper during ejection may cause a paper jam, paper cutting failure or line feed failure.

7-2. Removing Paper Jam

If a paper jam occurs, clear it as described below.

(1) Set the power switch to off to turn off power to the printer.

(2) Push the lever toward you to open the printer cover.

(3) Remove the jammed paper.

Note : To prevent parts such as the thermal head or the rubber roller from damage or deformation, do not forcibly pull on the paper with the printer cover closed.

(4) Position the paper roll straight and close the printer cover gently.

Note 1: Make sure that the paper is positioned straight. If the printer cover is closed with the paper skewed, a paper jam may result.

Note 2: Lock the printer cover by pressing down on the sides. Do not try to close it by pressing down on the centre. The cover may not lock properly.

(5) Set the power switch to on to turn on power to the printer. Make sure that the ERROR LED is not lit.

Note : While the ERROR LED is lit, the printer will not accept any commands such as the print command, so make sure that the printer cover is locked properly.

Caution Symbol



These labels are located near the thermal print head.

Because the thermal print head is hot immediately after printing, do not touch it. Static electricity can damage the thermal print head. To protect the thermal print head from static electricity, do not touch it.



This symbol is placed near the cutter.

Never touch the cutter blade, as you could injure your fingers.



This symbol is placed near the peripheral drive connector.

Do not connect this to a telephone.



This symbol label or stamp is placed near the screws securing the case or the protective plate, which should not be opened by individuals other than service personnel. Individuals, other than service personnel, should not remove these screws. High voltage areas in the case can be dangerous.

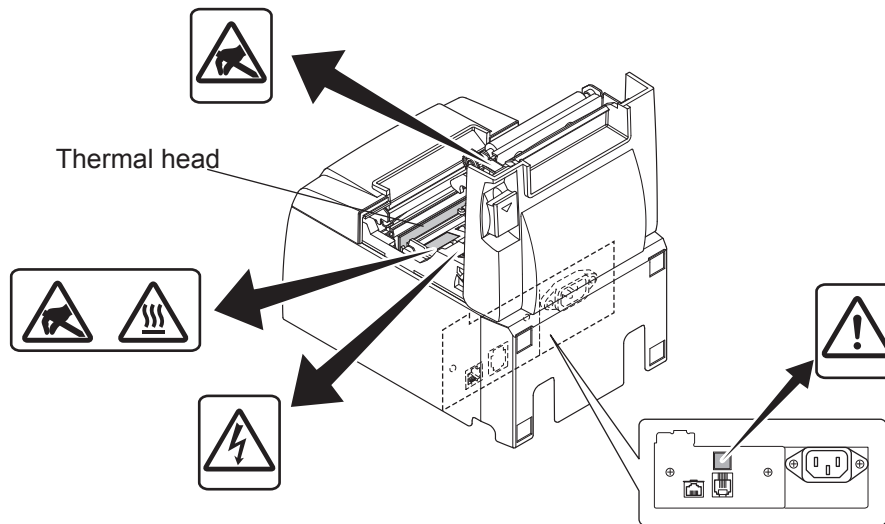

7-3. Releasing a Locked Cutter (Auto Cutter Mode only)

If the auto cutter locks up, set the power switch to OFF to turn off the printer, and then set the power switch to ON to turn the printer back on. A typical locked cutter will be restored when you restart the printer.

If restarting the printer does not release the locked cutter, follow the steps below.

⚠ WARNING

Since working on the cutter may be dangerous, be sure to turn off the printer first.

- (1) Set the power switch to OFF to turn off the printer.
- (2) Remove the front cover to reveal the auto cutter.
- (3) Remove any jammed paper.

Note: Be careful not to damage the printer while removing any jammed paper. Since the thermal print head is particularly sensitive, be sure not to touch it.

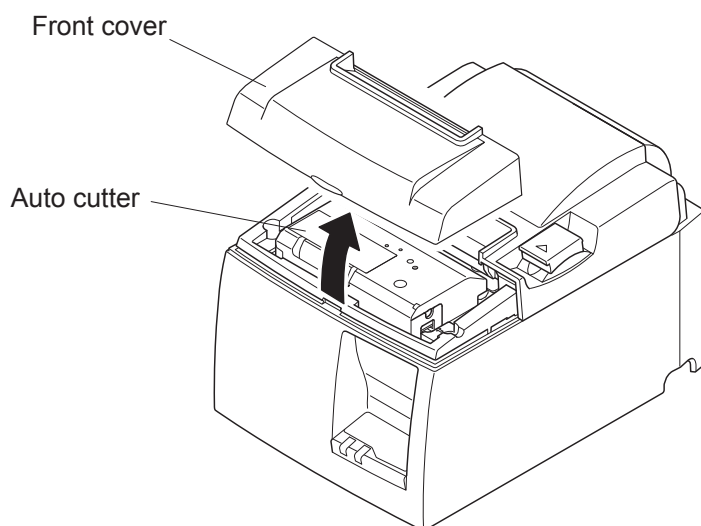

- (4) Insert a Philips screwdriver into the manual operation hole on the side of the cutter, and turn it in the direction of the arrow shown on the right until the rear cover is opened.
- (5) Open the printer cover, remove any jammed paper, and then reinstall the paper roll.
- (6) Install the front cover, and then set the power switch to ON.

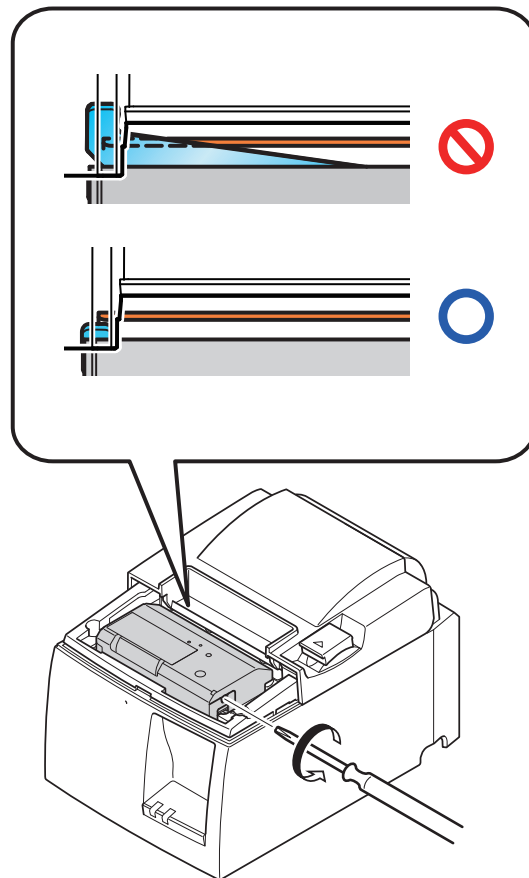

8. Periodical Cleaning

Printed characters may become partially unclear due to accumulated paper dust and dirt. To prevent such a problem, paper dust collected in the paper holder and paper transport section and on the surface of the thermal head must be removed periodically.

Such cleaning is recommended to be carried out once six month or one million lines.

8-1. Cleaning the Thermal Head

To remove the dark paper dust that has accumulated on the thermal head surface, wipe it clean with cotton swab (or soft cloth) dipped in alcohol (ethanol, methanol, or isopropyl alcohol).

- Note 1:** The thermal head is easily damaged, so clean it with a soft cloth, taking care not to scratch it.
- Note 2:** Do not attempt to clean the thermal head immediately after printing, when the thermal head is hot.
- Note 3:** Beware of the risk of damaging the thermal head as a result of static electricity that may be created during cleaning.
- Note 4:** Turn the power ON only after the alcohol has dried completely.

8-2. Cleaning the Rubber Roller

Use a dry, soft cloth to wipe off the dust that may have accumulated on the rubber roller. Rotate the platen to clean the entire surface.

8-3. Cleaning the Paper Holder and the Surrounding Area

Clean the paper holder of debris, dust, paper particles, glue, etc. that may have accumulated.

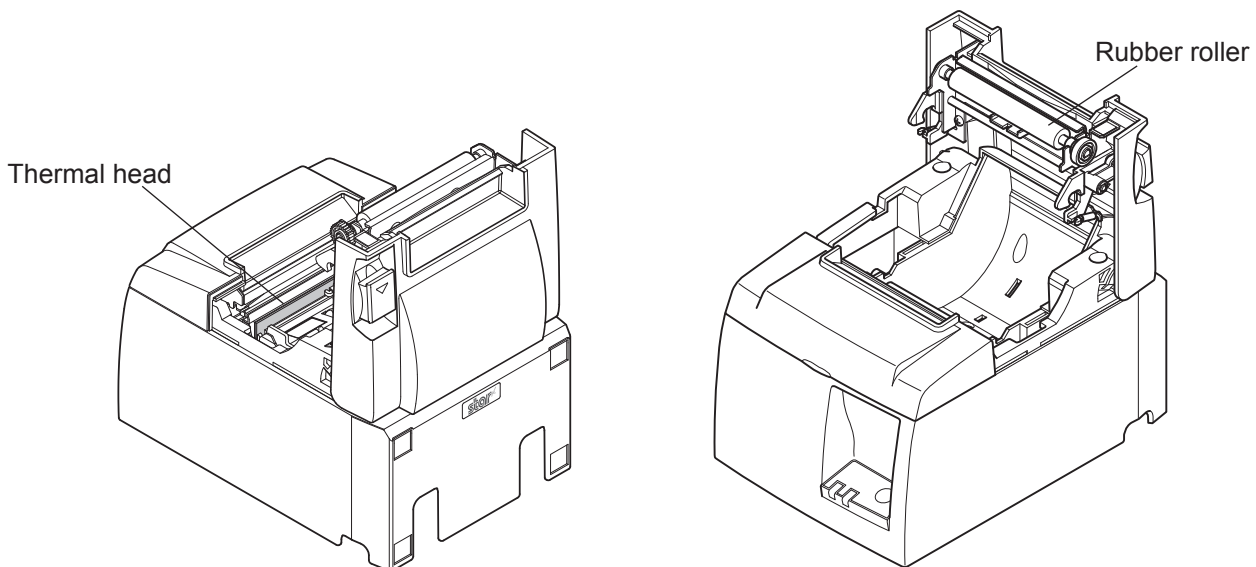

9. Peripheral Unit Drive Circuit

Peripheral unit drive circuit connector only connects to peripheral units such as cash drawers, etc. Do not connect it to a telephone.

Use cables which meet the following specifications.

Peripheral Drive Connector

Pin No.	Signal name	Function	I/O direction
1	FG	Frame ground	—
2	DRD1	Drive signal 1	OUT
3	+24 V	Drive power	OUT
4	+24 V	Drive power	OUT
5	DRD2	Drive signal 2	OUT
6	DRSNS	Sense signal	IN

Modular plug

Modular plug: MOLEX 90075-0007, AMP641337, or BURNDY B-66-4

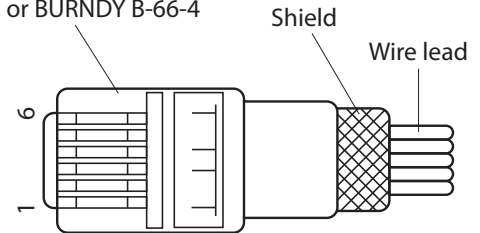

Drive circuit

The recommended drive unit is shown below.

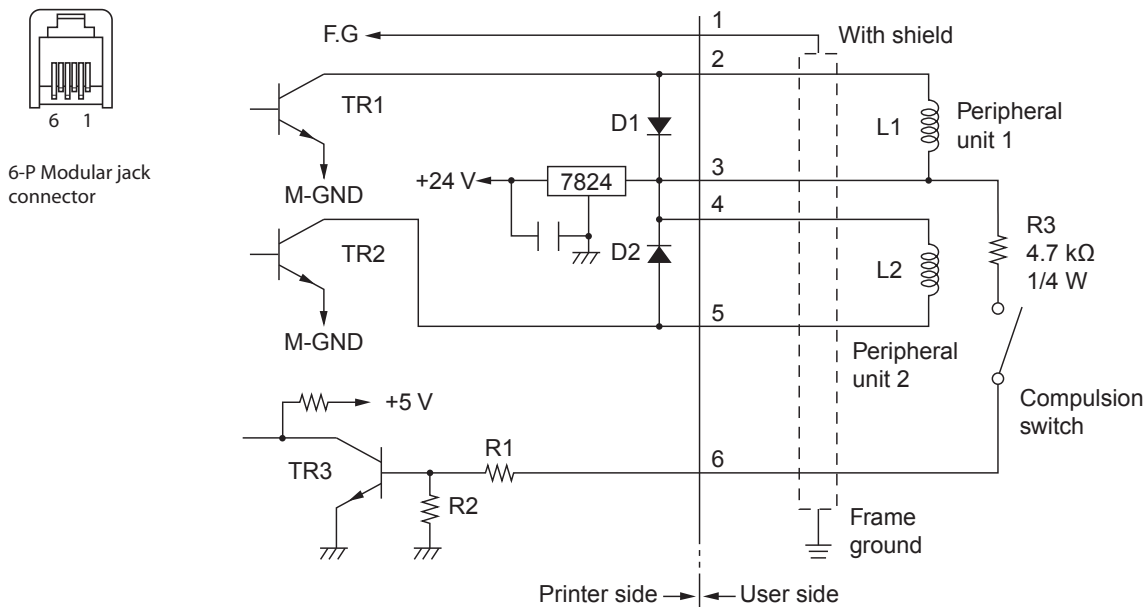

Reference
2SD 1866 Circuit Configuration

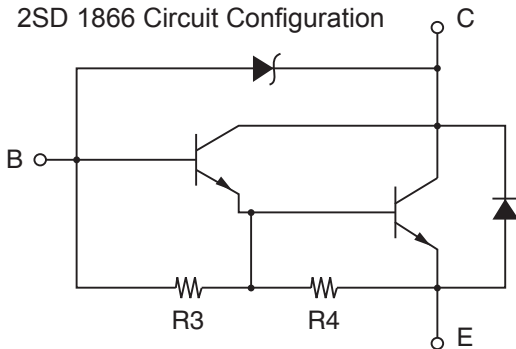

R3= 3.5 kΩ
R4= 300 W

Drive Output: 24 V, Max. 1.0 A
TR1, TR2: Transistor 2SD1866 or equivalent
R1=10 kΩ
R2=33 kΩ

- Notes:**
1. Pin 1 must be shield drain wire connected to peripheral device frame ground.
 2. It is not possible to drive two drives simultaneously.
 3. The peripheral drive duty must satisfy the following:
ON time / (ON time + OFF time) \leq 0.2
 4. Minimum resistance for coils L1 and L2 is 24 Ω .
 5. Absolute maximum ratings for diodes D1 and D2 ($T_a = 25^\circ\text{C}$) are:
Average Rectified Current $I_o = 1 \text{ A}$
 6. Absolute maximum rating for transistors TR1 and TR2 ($T_a = 25^\circ\text{C}$) are:
Collector current $I_c = 2 \text{ A}$

10. Specifications

10-1. General Specifications

- | | |
|-----------------------|-----------------------------------------------------------------------------------------------------------------------------------------------------------------------------|
| (1) Printing method | Direct line thermal printing |
| (2) Print speed | Max. 1000 dots/sec. (125 mm/sec.) |
| (3) Dot density | 203 dpi: 8 dots/mm (0.125 mm/dot) |
| (4) Printing width | Max. 72 mm |
| (5) Roll paper | Refer to chapter 5 for details on the recommended roll paper.
Paper width: 79.5±0.5 mm (57.5±0.5 mm when the paper roll holder is used)
Roll diameter: ø83 mm or less |
| (6) Overall dimension | 142 (W) × 204 (D) × 132 (H) mm |
| (7) Weight | Auto cutter model : 1.74 kg (without roll paper)
Tear bar model : 1.58 kg (without roll paper) |
| (8) Noise Approx. | 49 dB (Auto cutter model)
48 dB (Tear bar model) |

Note: The noise measurements listed above were obtained according to conditions established by this company. The noise measurements may vary depending on the type of paper used, type of printing, operating environment, and power consumption mode.

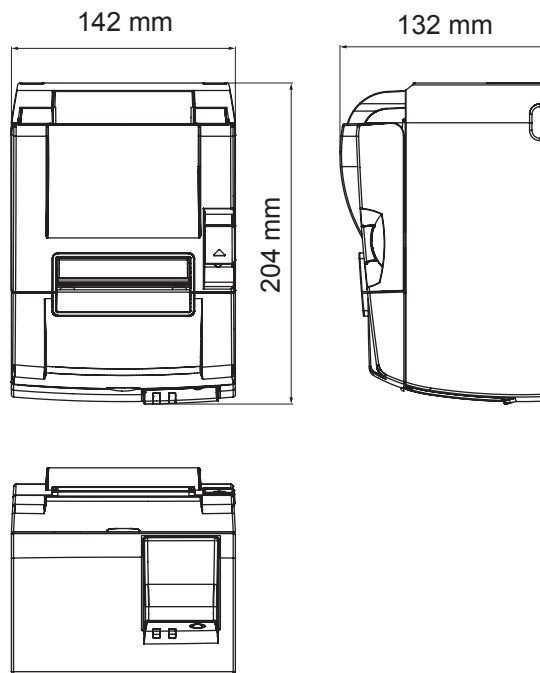

10-2. Auto Cutter Specifications

- (1) Cutting frequency Max. 20 cuts per minute
- (2) Thickness of paper 65~85 μm

10-3. Ethernet Interface

- (1) General Specification Conforms to IEEE802.3 / Conforms to IEEE802.3u
- (2) Communication Media 10 Base-T / 100 Base-TX
- (3) Communication Speed 10 / 100 Mbps
- (4) Protocol TCP/IP v4
- (5) TCP/IP detail ARP , IP , ICMP , TCP , UDP , DHCP , BOOTP , #9100 , SDP ,
 TELNET
- (6) Connector RJ-45 (8-pin modular)

Pin No.	Signal name	Function
1	TX+	Transmit Data +
2	TX-	Transmit Data -
3	RX+	Receive Data +
4-5	-	-
6	RX-	Receive Data -
7-8	-	-

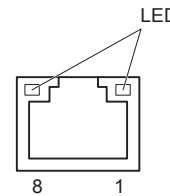

- (7) LED Display
 - Green Lights when other party connection is recognized as 100BASE-TX.
 - Red Lights when packets are received.

10-4. Electrical Characteristics

- (1) Input Voltage 100 to 240 V AC, 50/60 Hz
- (2) Current Consumption Operating: Approx. 40 W (at ASCII printing)
 Stand-by: Approx. 6 W

10-5. Environmental Requirements

(1) Operating
Temperature
Humidity

5°C to 45°C
10% to 90% RH (without condensation)

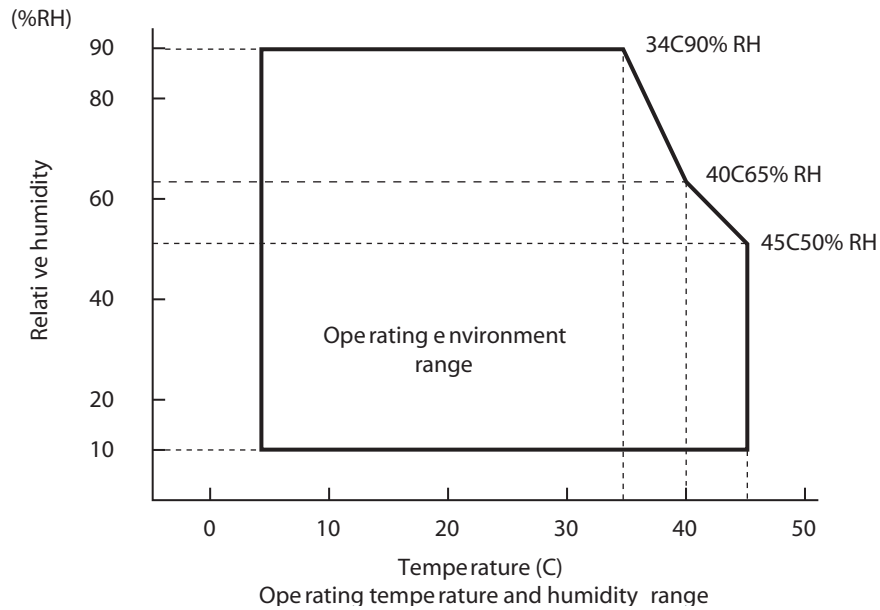

(2) Transport/storage (except for paper)

Temperature
Humidity

-20°C to 60°C
10% to 90% RH (without condensation)

10-6. Reliability

- 1) Life Mechanical : 20 million lines
Head : 100 million pulses, 100 km
(±15% max. average head resistance fluctuation)
For 2-color printing, 50 million pulses, 50 km
(±15% max. average head resistance fluctuation)
Auto cutter : 1 million cuttings
(provided the paper thickness is between 65 and 85 μm)

<Conditions>

Average printing ratio : 12.5%

Recommended thermal paper : 65 μm

- 2) MCBF: 60 million lines

The Mean Cycle Between Failure (MCBF) is defined to be the overall failure cycle, which includes random or wear failures that occur until the printer reaches its mechanical life of 20 million lines.

* As the mechanical remains at 20 million lines, the MCBF of 60 million lines does not indicate its useful life.

- 3) Auto Cutter (Life)

1 million cuttings (provided the paper thickness is between 65 and 85 μm)

* All the reliability values indicated above are based on the use of the recommended thermal paper. No reliability can be guaranteed for the use of non-recommended thermal paper.

11. DIP Switch Settings

There are DIP switches located on the bottom of the printer and various settings can be performed as shown in the following table.

When changing the settings, use the following procedure.

- (1) Turn the printer off and disconnect the power cable plug from the AC outlet.
- (2) Remove the screw, and then remove the DIP switch cover on the bottom of the printer.

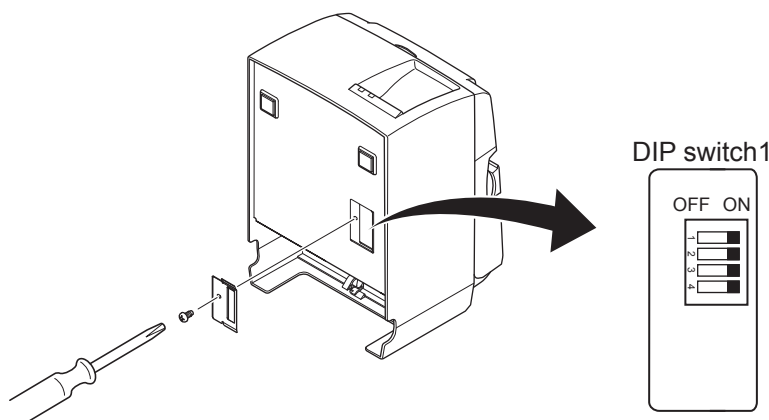

- (3) Use a tool with a narrow tip to change the DIP switch settings.
- (4) Install the DIP switch cover and secure it with the screw.

Note: The new settings will take effect after the printer is turned on.

DIP Switch 1

Switch	Function	ON	OFF
1-1	Reserved	Fixed	-
1-2	Reserved	Fixed	-
1-3	IP address acquisition time-out setting *2	20 seconds	No time-out
1-4	Initialize network settings *1	Valid	Invalid

The factory settings of DIP Switch are all on.

(*1)

Initialize network settings procedure

1. Turn the printer off.
2. Set DIPSW1-4 to OFF when the power is on, and wait for approximately 15 seconds.
3. Set DIPSW1-4 to ON to turn the power on again.

Note: Because the following functions are unavailable when DIPSW1-4 is set to OFF, make sure you set DIPSW1-4 to ON.

- Printing (self-print is available)
- TELNET server

(*2)

Sets the timeout time when getting the address from a DHCP server. The factory default setting (when set to ON) is 20 seconds.

When set to on, there is no timeout.

If this product is connected directly to an intelligent switch or intelligent hub, the physical link may take some time to become established. As a result, a timeout will occur while waiting to get the DHCP address, and it will fail to get the IP address. In such cases, set DIPSW1-3 = OFF to have no IP address acquisition timeout.

Note: This feature is supported from firmware version 3.0.

For the printer's firmware, contact your dealer.



URL: <http://www.starmicronics.com/support/>